



PARK AND CHARGE STANDS

Carney Battery Handling offers a wide range of park and charge stands to suit multiple charger configuration suited to various facility layouts.

Our opportunity charging stations and floor mount charger shelves can be completely customized for various widths, heights and shelves and shelf configurations.

GET IN TOUCH

info@carneyfabricating.com
www.carneyfabricating.com

Tel: 1.905.564.0303
Toll free: 1.866.THE.BULL

2A - 14 Reagan Road
Brampton Ontario L7A 1B9

Charger Stands

CONFIGURABLE CHARGER STANDS WITH CUSTOM HEIGHTS, WIDTHS AND SHELVING

Versa Stand

The Versa Stand is an easily configurable charger stand that can be modified to fit any specific brand of chargers. The low-cost stand is designed for simple disassembly for compact shipping and transportation, and is finished in acid proof powder coating for long-lasting durability.



FM-HF-HAW-69-1525



FM-HF-HAW-69-1525

Floor Mount Charger Shelf (FM-CS)

- Standard depth 30"
- Standard height 42"
- Custom widths up to 96" and 30" deep to support all common chargers Maximum 48" span between uprights
- All welded construction
- Finished in acid proof powder coating



FM-CS-30-40-2H



FM-CS-30-36-42H



Floor Mount Charger Shelf

High Frequency Charger Stands

- High Frequency Charger Stand with 2 Shelves positioned both at the front (FF) or on the opposite sides (BB) available
- Custom widths up to 96" and 30" deep to support all common chargers
- All welded construction
- Finished in acid proof powder coating
- Custom height available



(FM-CS-HF-CRMB) high frequency, charger stand



(FM-CS-HF-ECL-II-S2-BB) with capacity of 150 lbs per shelf



FM-CS-HF-ECL-II-S2-FF



Custom Charger Stand design

Custom Designs Available!

CONFIGURABLE CHARGER STANDS WITH CUSTOM HEIGHTS, WIDTHS AND SHELVING

Supported by experienced engineers and mechanical professionals, we are able to offer our customers comprehensive services that include design and build of any custom charger stand equipment.

Our configurable charger stands are crafted with expertise and attention to detail. From conception, design, testing and final execution, our products are built with our customers in mind.

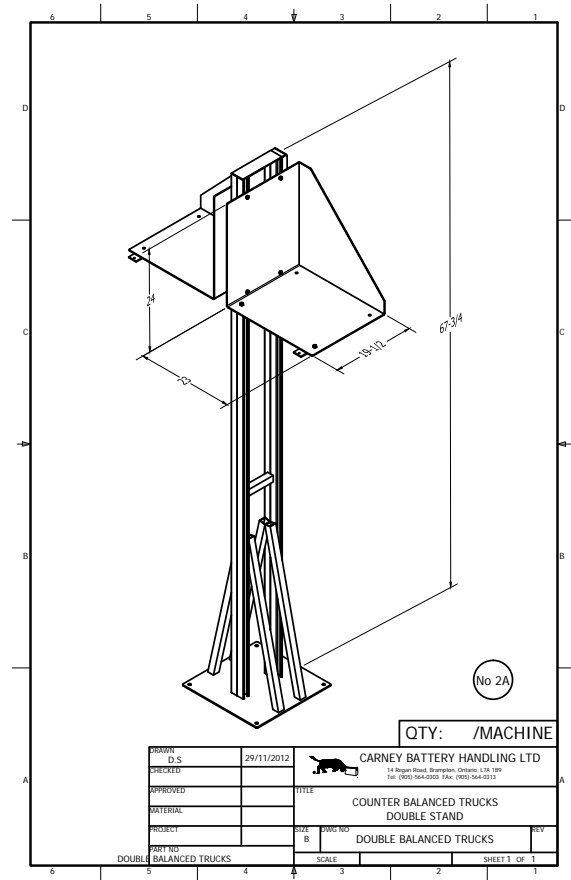
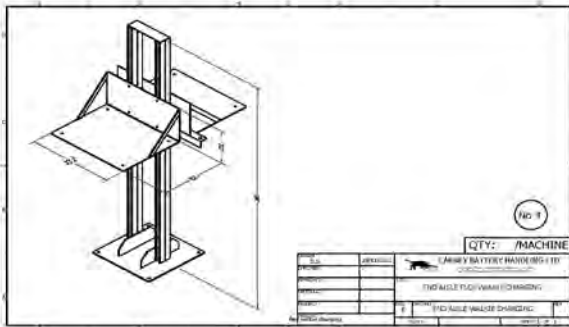
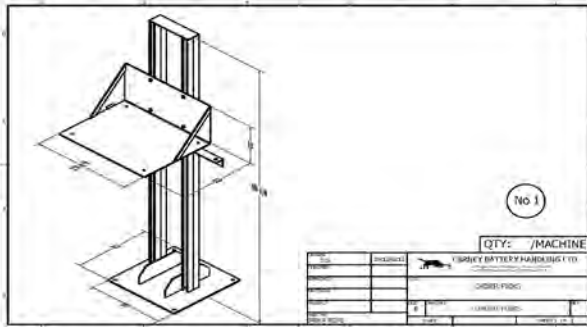

PRODUCT SPECIFICATIONS

Maximum Lift Capacity	150 lbs per shelf
Standard Height	42"
Standard Width	26" - 96"
<i>Custom units available</i>	

GET IN TOUCH

info@carneyfabricating.com
www.carneyfabricating.com

Tel: 1.905.564.0303
Toll free: 1.866.THE.BULL

2A - 14 Reagan Road
Brampton Ontario L7A 1B9