



BATTERY WASH SYSTEM

For small fleets with infrequent washing needs, CBH's semi-automatic wash station provides an efficient and cost effective solution to keep your batteries operating at their peak. The BWS allows for both roll-out and lift-out systems with a full range of matched consumables and can be integrated with our Wastewater Treatment System (WWTS) to provide a closed-loop battery washing system that does not require drainage.

GET IN TOUCH

info@carneybatteryhandling.com
www.carneybatteryhandling.com

Tel: 1.905.564.0303
Toll free: 1.866.THE.BULL

2A - 14 Reagan Road
Brampton Ontario L7A 1B9

Battery Wash System

Features and Benefits

- Heavy duty stainless steel construction

The BWS is durably built to last and composed of heavy duty stainless steel

- Power washer included

Includes independent 1700 PSI power washer with handheld wand

- Suits roll-in or gantry loading of batteries

Our BWS can be loaded in a variety of ways including overhead or by roll-in

- Built in safety

This wash system has ground fault shutdown and water overflow protection built in

- Digital PH display

that automatically dispenses neutralizer & a built in clear digital PH meter allows precise PH monitoring for automated neutralization

- WWTS Compatible

The BWS is compatible with the CBH Waste Water Treatment System to support closed loop washing

- Integrated splash guards

Built in splash guards keep the operator safe and dry

- Simple PLC Interface

provides an assortment of programming options including; washing and drying cycles, to suit your fleet and schedules

- Adjustable legs for levelling

Equipped with adjustable legs the BWS can accommodate a variety of washing locations giving you a level wash everytime

- Environmental Regulations

When used with the CBH WWTS the BWS meets the environmental regulation for battery washing

Available Options

OPTIONS

Wastewater treatment integration

Battery Wash System

DIMENSIONS

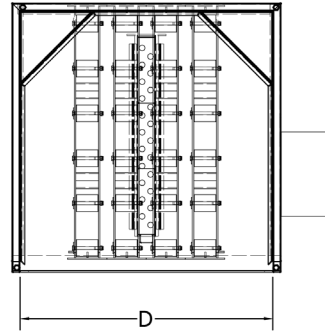

* RB OPTION SHOWN

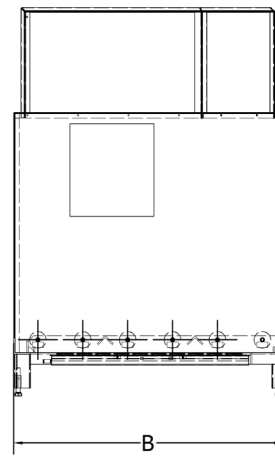
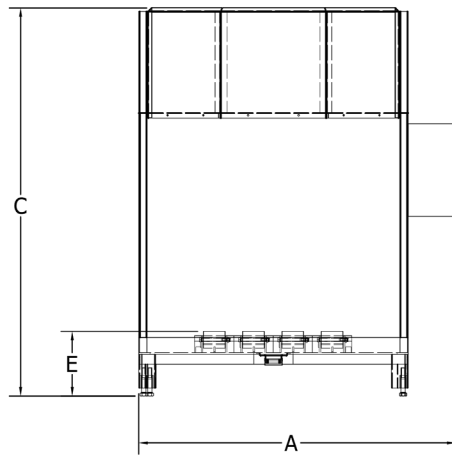

Battery Wash System

3D RENDERING

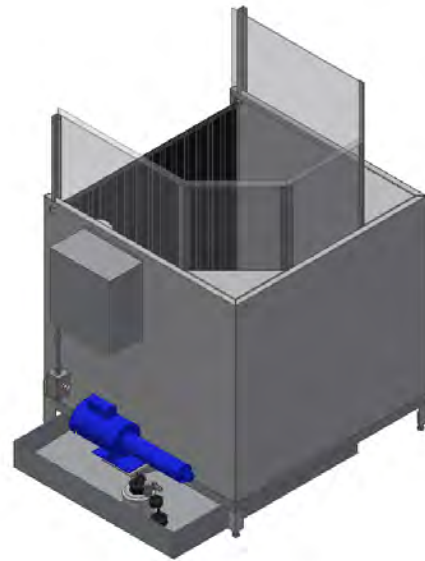
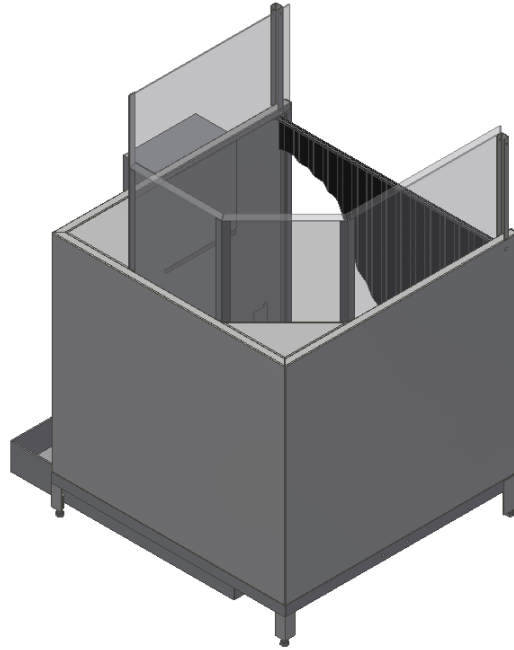

Battery Wash System

SPECIFICATIONS

BASIC DIMENSIONS (REFER TO DIAGRAM ON PAGE 3)

A	Overall width	56.5"	1435 mm
B	Overall Depth	48"	1219 mm
C	Overall Height	70"	1778 mm
D	Door Access Size	45"	1143 mm
E	Roll-off Height	14.5"	368 mm
F	Booth Size Inside	46" W x 45" D	40.5/1029

GENERAL SEPECIFICATIONS

1	Power	120 VAC/1 Phase/ 30 AMP	
2	Operation	Semi-Automatic	
3	Capacity	6000 lbs	2727 kg
4	Performance	1700 PSI	
5	Booth Construction	14 gauge stainless steel	
6	Legs (adjustable for leveling)	+/- 0.50"	+/- 13 mm
7	Door	Curtain	
8	Weight (dry)	642 lbs	292 kg
9	Loading	Roll-in or overhead	

Model/Part Number Breakdown

Example: BWS-RB

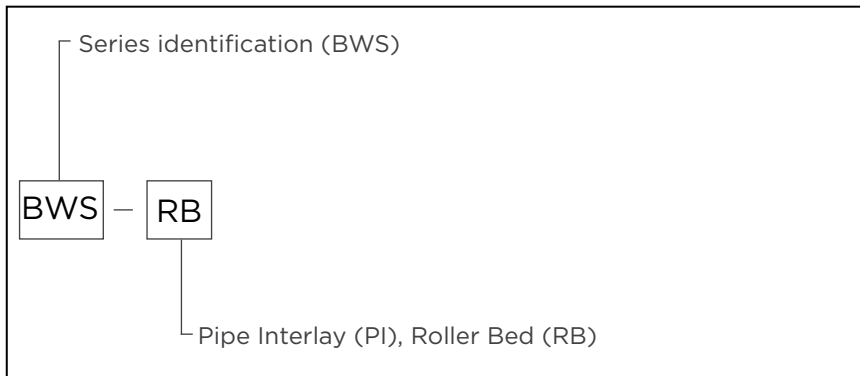

BWS - accompanied by attachable WWTS (Wastewater Treatment System)

GET IN TOUCH

info@carneybatteryhandling.com
www.carneybatteryhandling.com

Tel: 1.905.564.0303
Toll free: 1.866.THE.BULL

Due to continuous product improvements, specifications are subject to change without notice. Some systems and features shown may be optional at extra cost.

CBH_BWS_NA_R003