



GANTRY CRANE

Even with the increased use of the roll-out battery extraction, there remains a need for safe, reliable and effective lift-out gantry systems to support legacy and specialized equipment.

CBH's range of gantry cranes are available in both fixed and mobile configuration with manual and hydraulic drive. Our unique hydraulic drive system uses positive traction on both sides to reduce twisting and frame stress. This only requires a floor guide on one side, which allows for better workspace utilization. We also offer solutions for permanent floor mounting, reversed braces, cantilever or uneven floor requirements.

A full range of sizes and capacities are available to support all battery fleets with tightly integrated safety and protection systems for both operators and assets.

GET IN TOUCH

info@carneybatteryhandling.com
www.carneybatteryhandling.com

Tel: 1.905.564.0303
Toll free: 1.866.THE.BULL

2A - 14 Reagan Road
Brampton Ontario L7A 1B9

Gantry Crane

Features and Benefits

- Lifting capacities up to 3 tons (6000 lbs)
Our gantry cranes can accommodate a variety of lifting capacities dependant on operational needs

- Standard spans up to 30 feet
A variety of lengths are available up to a maximum of 30 feet

- Exterior coating and stainless steel motors
Built for indoor or outdoor applications

- Portable Gantries
Quickly disassembled for transport by a service truck with a portable gantry crane

- A tagline or festoon system
Outfit your crane with a festoon or tagline system to deliver electrical power to your hoist or trolley

- Simple height and span adjustments
Safely adjust height and span of the crane

- Powered travel / CE approved
CE approved and electrically powered floor travel available with any system.

- Ideal for warehouses and welding shops
Perfect for small spaces and warehousing applications

- In accordance with current safety standards
Designed to meet current North American Standards

- Ergonomic dash panel and control station
Dashboard and control station designed for operator comfort

Available Options

OPTIONS
Radio remote controls
Available in permanent floor-mounting or on-rail models
Adjustable height, span, and tread (T-series)
Customization of heights and weight capacity available

Gantry Crane

DIMENSIONS

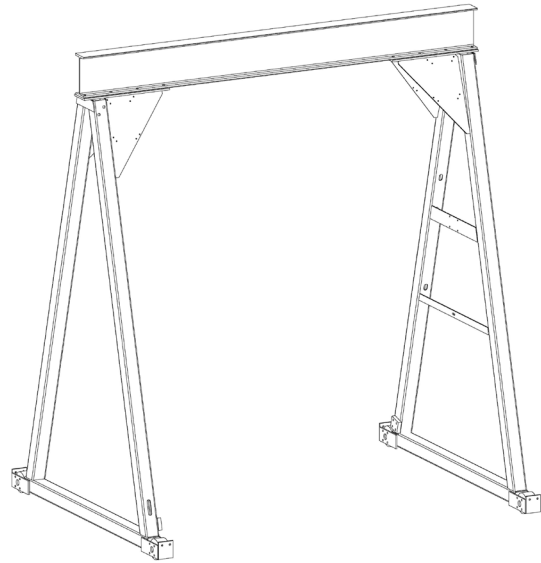
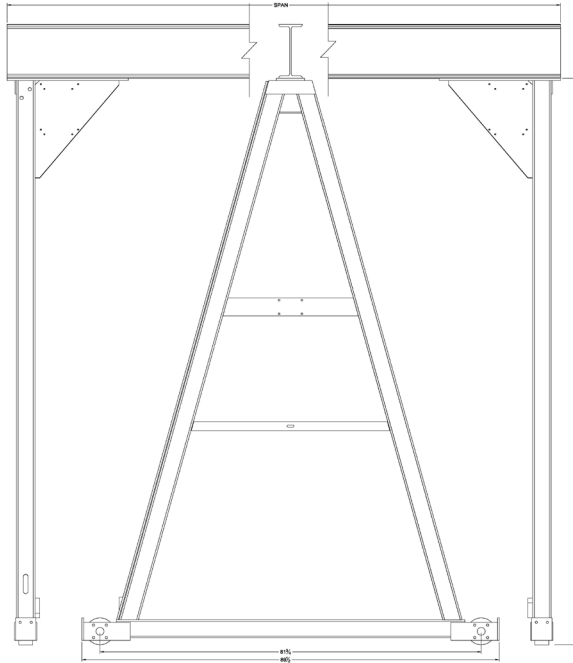

Gantry Crane

SPECIFICATIONS

CAPACITY (Tons)	MODEL	TYPE	CLEARANCE (Beam)	LENGTH (FT)
2	SGC-10-10-2	Stationary	10'- 6"	10'
	SGC-10-12-2	Stationary	10'- 6"	12'
	SGC-10-14-2	Stationary	10'- 6"	14'
	SGC-10-16-2	Stationary	10'- 6"	16'
	SGC-10-18-2	Stationary	10'- 6"	18'
	SGC-10-22-2	Stationary	10'- 6"	22'
	SGC-10-24-2	Stationary	10'- 6"	24'
	SGC-10-26-2	Stationary	10'- 6"	26'
	SGC-10-28-2	Stationary	10'- 6"	28'
	SGC-10-30-2	Stationary	10'- 6"	30'
SGC-10-32-2	Stationary	10'- 6"	32'	
2	MGC-10-10-2	Manual	10'- 6"	10'
	MGC-10-12-2	Manual	10'- 6"	12'
	MGC-10-14-2	Manual	10'- 6"	14'
	MGC-10-16-2	Manual	10'- 6"	16'
	MGC-10-18-2	Manual	10'- 6"	18'
	MGC-10-20-2	Manual	10'- 6"	20'
2	HGC-10-10-2	Hydraulic	10'- 6"	10'
	HGC-10-12-2	Hydraulic	10'- 6"	12'
	HGC-10-14-2	Hydraulic	10'- 6"	14'
	HGC-10-16-2	Hydraulic	10'- 6"	16'
	HGC-10-18-2	Hydraulic	10'- 6"	18'
	HGC-10-20-2	Hydraulic	10'- 6"	20'
	HGC-10-22-2	Hydraulic	10'- 6"	22'
	HGC-10-28-2	Hydraulic	10'- 6"	28'
3	SGC-10-10-3	Stationary	10'- 6"	10'
	SGC-10-12-3	Stationary	10'- 6"	12'
	SGC-10-14-3	Stationary	10'- 6"	14'
	SGC-10-16-3	Stationary	10'- 6"	16'
	SGC-10-18-3	Stationary	10'- 6"	18'
	SGC-10-23-3	Stationary	10'- 6"	23'
3	MGC-10-10-3	Manual	10'- 6"	10'
	MGC-10-12-3	Manual	10'- 6"	12'
	MGC-10-14-3	Manual	10'- 6"	14'
	MGC-10-16-3	Manual	10'- 6"	16'
	MGC-10-18-3	Manual	10'- 6"	18'

Gantry Crane

CAPACITY (Tons)	MODEL	TYPE	CLEARANCE (Beam)	LENGTH (FT)	VOLTAGE
3	HGC-10-10-3-xxx	Hydraulic	10'- 6"	10'	415/480/575
	HGC-10-12-3-xxx	Hydraulic	10'- 6"	12'	415/480/575
	HGC-10-14-3-xxx	Hydraulic	10'- 6"	14'	415/480/575
	HGC-10-16-3-xxx	Hydraulic	10'- 6"	16'	415/480/575
	HGC-10-18-3-xxx	Hydraulic	10'- 6"	18'	415/480/575
	HGC-10-20-3-xxx	Hydraulic	10'- 6"	20'	415/480/575
	HGC-10-22-3-xxx	Hydraulic	10'- 6"	22'	415/480/575
	HGC-10-24-3-xxx	Hydraulic	10'- 6"	24'	415/480/575

HOISTS & TROLLEYS

CAPACITY (Tons)	TYPE	SPEED	VOLTAGE
2	Manual hoist / trolley	Single	-
	Electric hoist / push trolley	Single	415/480/575
	Electric hoist / electric trolley	Single	415/480/575
	Electric hoist / push trolley	Double	415/480/575
	Electric hoist / electric trolley	Double	415/480/575

CAPACITY (Tons)	TYPE	SPEED	VOLTAGE
3	Manual hoist / trolley	Single	-
	Electric hoist / push trolley	Single	415/480/575
	Electric hoist / electric trolley	Single	415/480/575
	Electric hoist / push trolley	Double	415/480/575
	Electric hoist / electric trolley	Double	415/480/575

Model/Part Number Breakdown

Example: HGC-10-18-2-480

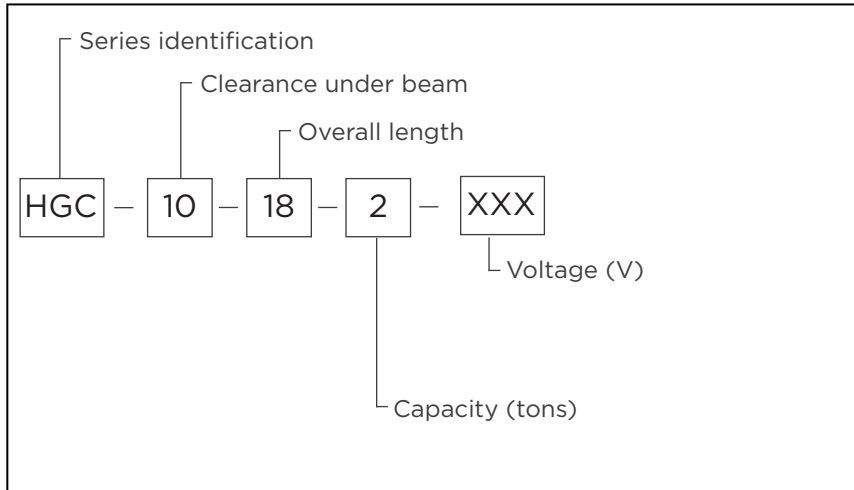

Gantry crane full front view with hoist



Gantry crane hoist controller

GET IN TOUCH

info@carneybatteryhandling.com
www.carneybatteryhandling.com

Tel: 1.905.564.0303
Toll free: 1.866.THE.BULL

Due to continuous product improvements, specifications are subject to change without notice. Some systems and features shown may be optional at extra cost.

CBH_HGC_NA_R003