



BTM

BATTERY TUGGER MANUAL

SWAPPING BATTERIES SINCE 1984





BTM

BATTERY TUGGER MANUAL

The simple pallet truck design and solid wheels make the CBH Manual Battery Tugger as simple to operate as any standard pallet truck. Easy to turn and move while fully loaded, this unit comes equipped with a battery safety stop and a ratchet crank handle to prevent slipping.

Able to load and unload batteries entirely solo, the BTM is a compact unit ready to tackle day-to-day battery maintenance for operators and service technicians everywhere. This unit is available in two convenient sizes to accommodate a wide range of battery sizes 24" or 36".

MANUALLY ACTIVATED

Completely manual and easy to use the BTM has been engineered for zero pushback while changing

STAND-ALONE

This unit is completely independent and does not require a fork truck. It's manual design makes it easier for anyone to swap a battery.

EASY TO OPERATE

Two fixed front casters and two swivel casters in the rear make the BTM easy to operate, and its convenient waist-high design offers lifting and lowering using only hand controls.

WARRANTY

Every unit comes with a standard 1-year warranty for your protection.

LIFTING RANGE

The BTM comes equipped with a lifting range of 4"-22.5" or 102 - 572 mm.

FOR SMALLER OPERATIONS

This unit is ideal for operations with smaller forklift fleets helping forklift drivers of all ages service batteries.



KEY FEATURES + OPTIONS

- ✓ Custom colours available
- ✓ Hand crank activated positive braking system
- ✓ Ratchet crank handle
- ✓ Durable rollers
- ✓ Battery safety stop
- ✓ Affordable & compact
- ✓ Integrated hand pallet truck lift mechanism
- ✓ Single point push/pull travel
- ✓ Manual foot brake
- ✓ Fixed & swivel casters
- ✓ Extension limiter
- ✓ Available in size 24" or 36" wide

GENERAL SPECS

Capacity	3,200 lbs / 1,451 kgs
Service weight	778 lbs / 354 kgs
Standard Colours	Orange
Battery connection type	Manual chain hook

MODEL-PART NUMBER BREAKDOWN

Example: BTM-24-ML-4-22

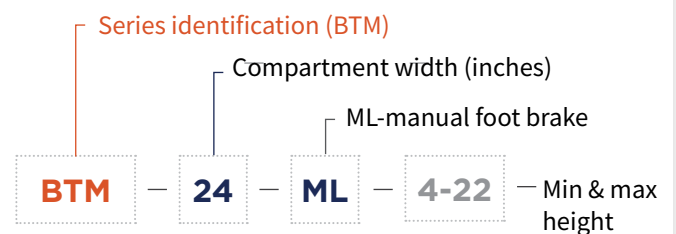

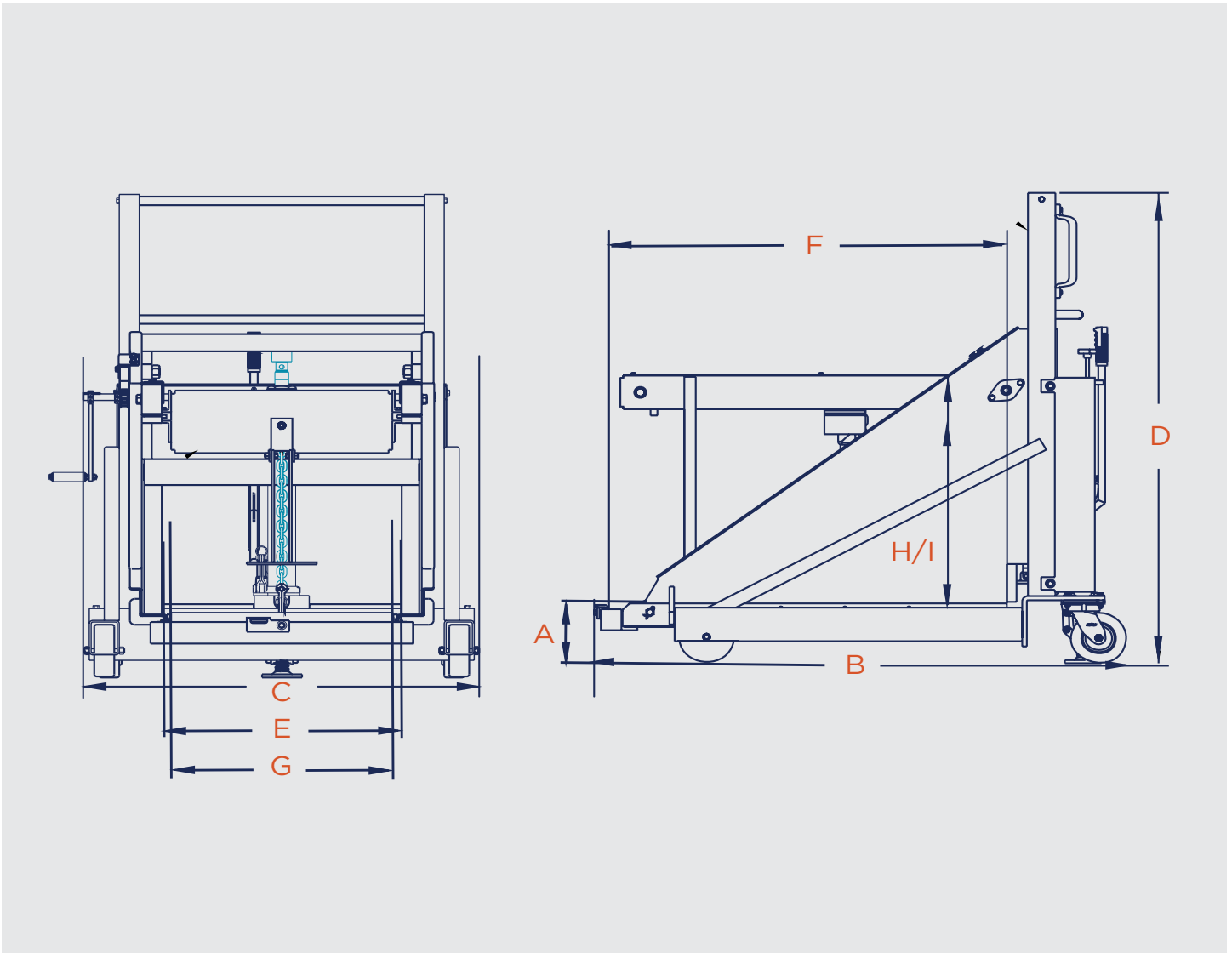

DIMENSIONAL DATA

BTM-24

BTM-36

A	Roll-out height	4"/102 mm	
B	Overall length	58"/1473 mm	
C	Overall width	41"/1041 mm	53"/1346 mm
D	Overall height	55.5"/1410 mm	
E	Battery compartment width	24"/610 mm	36"/914 mm
F	Maximum battery length	40"/1016 mm	
G	Maximum battery width	23"/584 mm	35.5"/902 mm
H	Maximum battery height	32"/813 mm	
I	Minimum battery height	20"/508 mm	



FABRICATING & AUTOMATION

Our specialized team of machinists create tools, parts, products, and attachments to solve everyday material handling dilemmas while our team of automation experts focus on robotic engineering, PLC and HMI programming and process automation geared towards your specific manufacturing needs. We deliver world-class expertise by innovating products that help you meet the demands of day-to-day operations.

Let's get started on your next project.



- ✓ Operational Up-time
- ✓ In-house Manufacturing
- ✓ Safety & Security

- ✓ Automated Battery Handling
- ✓ System Design
- ✓ And more!

info@carneyautomation.com

CARNEYAUTOMATION.COM



- ✓ Product Transfer Systems
- ✓ Below-The-Hook Devices
- ✓ Storage Systems

- ✓ Ergonomic Equipment
- ✓ Forklift & Picker Attachments
- ✓ And more!

info@carneyfabricating.com

CARNEYFABRICATING.COM



HAVE ADDITIONAL QUESTIONS? GET IN TOUCH

sales@carneybatteryhandling.com
www.carneybatteryhandling.com

Tel: 1.905.564.0303
Toll free: 1.866.THE.BULL

Due to continuous product improvements, specifications are subject to change without notice. Some systems and features shown may be optional at extra cost.

©2024 Carney Battery Handling Ltd.
BTM_specifications_NA