

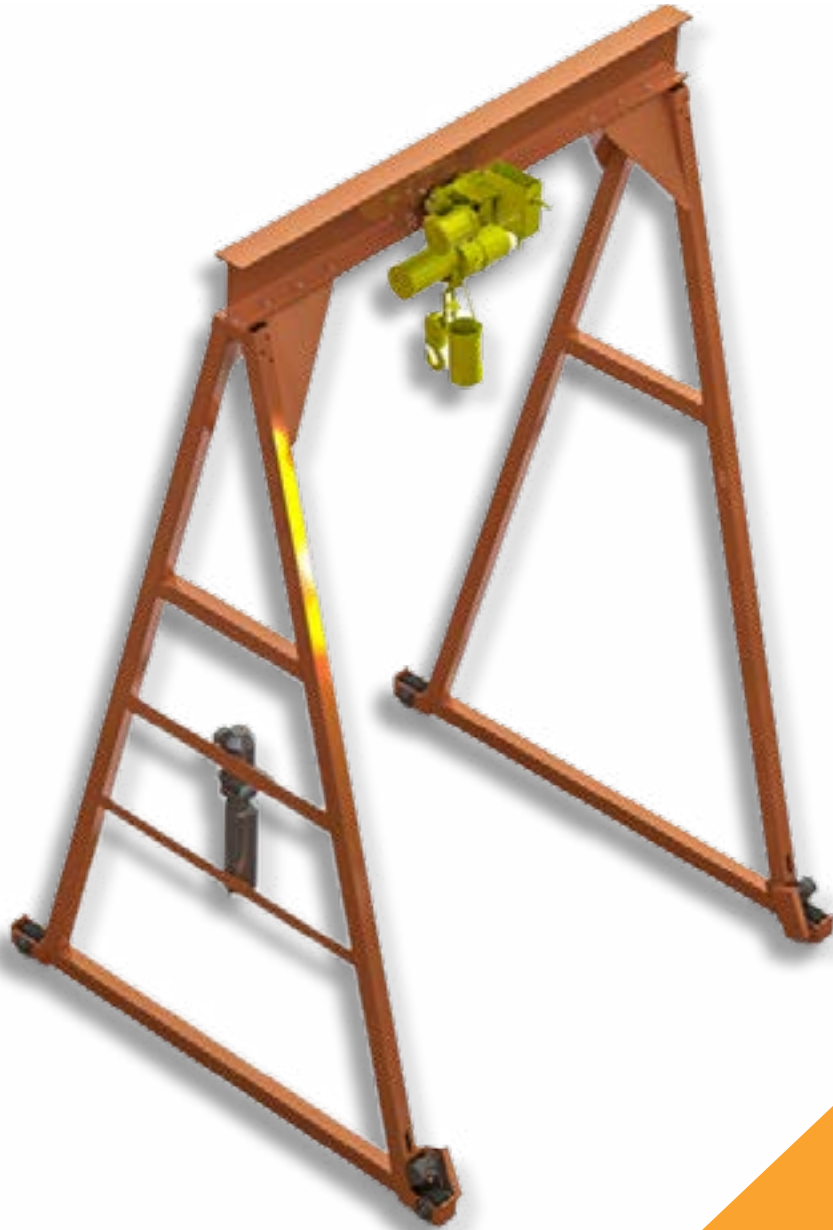

# HGC

## HYDRAULIC GANTRY CRANE

EASY, LIFT-OUT BATTERY MANAGEMENT





# HYDRAULIC GANTRY CRANES

Despite the increased use of roll-out battery extraction, there is still a need for safe, reliable, and effective lift-out gantry systems to support legacy and specialized equipment. CBH offers a range of gantry cranes in both fixed and mobile configurations, with manual and hydraulic drive options. Our unique hydraulic drive system utilizes positive traction on both sides to reduce twisting and frame stress, requiring only a floor guide on one side for better workspace utilization.

Additionally, we offer solutions for permanent floor mounting, reversed braces, cantilevers, or uneven floor requirements.

## **SUPPORTIVE & EFFICIENT**

Our range of sizes and capacities can support all battery fleets, while tightly integrated safety and protection systems provide peace of mind for both operators and assets.

## **HEAVY LIFTING**

With lifting capacities up to 3 tons available. We offer cranes that help you lift even the heaviest batteries.

## **FLEXIBLE MOUNTING**

Custom options for floor mounting, reversed braces, cantilever or uneven floors.

## **PERFECT FOR OPERATORS**

User friendly, our hydraulic gantry cranes are easy to operate and outfitted with hoists that are reliable and simple to service.

## **COMPACT UNITS FOR WORKSTATIONS**

We manufacture cranes for material handling in workstations too and use the same designs in our warehouses.



## KEY FEATURES + OPTIONS

- ✓ Custom colours available
- ✓ Full range of sizes up to 22' span and 12' clearance
- ✓ 1-year hoist warranty
- ✓ Built for indoor or outdoor use
- ✓ Ergonomic dash panel & control station
- ✓ CE Approved
- ✓ Powered floor travel available with any unit
- ✓ Radio remote control & safety sensors
- ✓ Adjustable height, span & tread available
- ✓ Exceeds OSHA regulations
- ✓ Manual & stationary models available
- ✓ Manual & electric hoists available

## GENERAL SPECS

Capacity	6,000 lbs / 2,722 kgs
Hoist Type	Manual/Electric
Standard Colours	Orange / Yellow
Voltage	415/480/575

## MODEL-PART NUMBER BREAKDOWN

Example: HGC-10-10-2-XXX

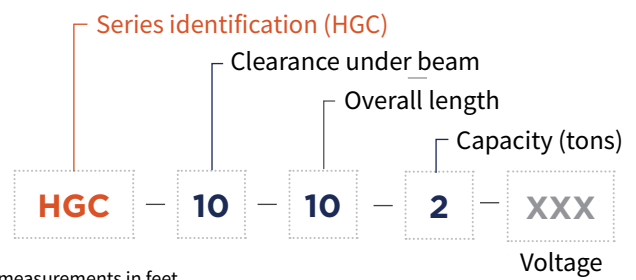

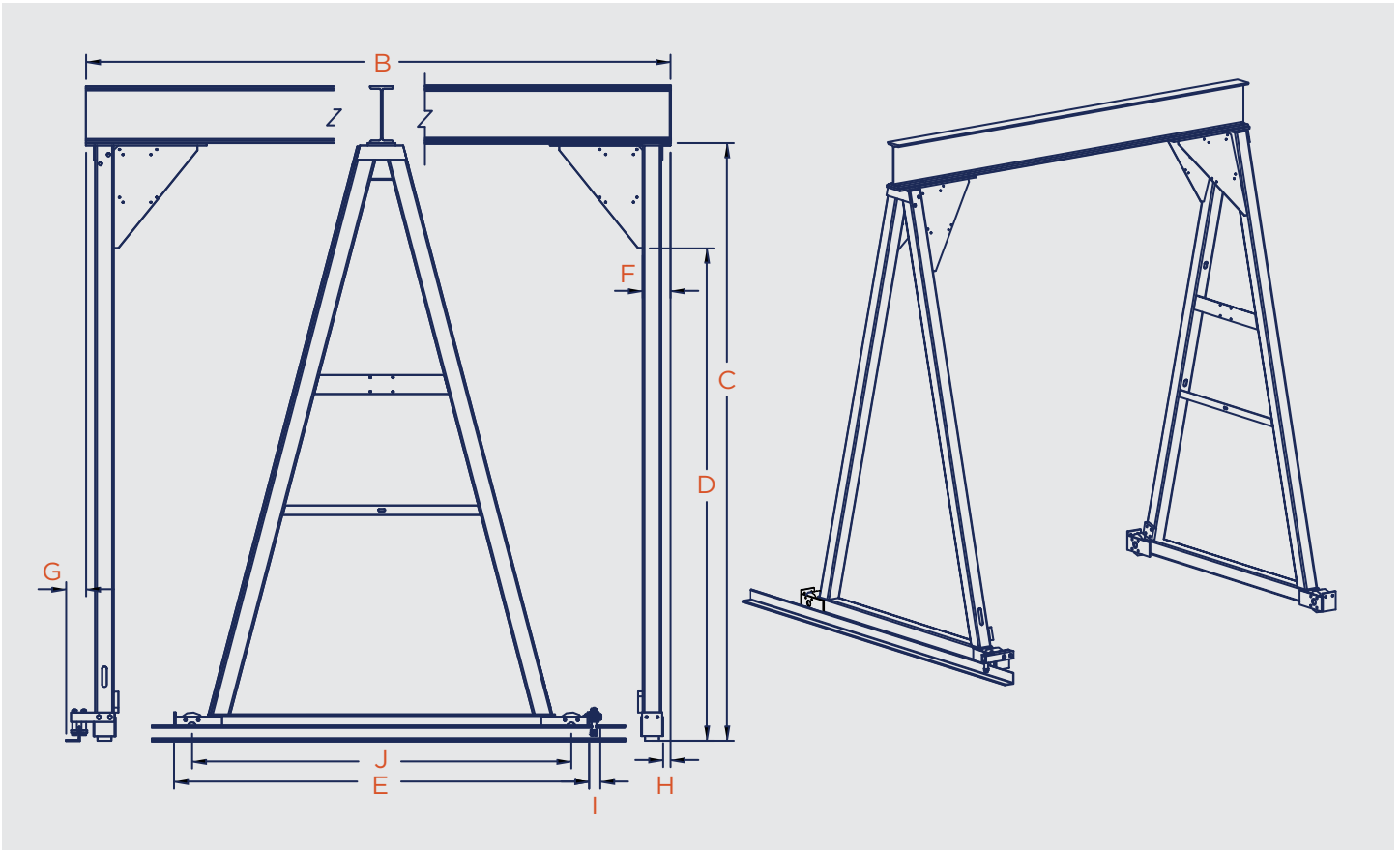

### DIMENSIONAL DATA

#### HGC -1

#### HGC-2

#### HGC-3

	Standard capacity	1-TON	2-TON	3-TON
<b>B</b>	Overall span	10-32'	10-28'	10-24'
<b>C</b>	Overall height	126"/ 3201 mm		
<b>D</b>	Overall height (under beam)	120"/ 2637 mm		
<b>E</b>	Overall width (A-frame)	90"/ 2273 mm		
<b>F</b>	Width of beam	6"/ 152 mm		
<b>G</b>	Guide side clearance	4.25"/ 110 mm		
<b>H</b>	Opposite side clearance	1.6"/ 41.27 mm		
<b>I</b>	Sensor clearance	2.3"/ 61 mm		
<b>J</b>	Wheel base		82"/ 2076 mm	





# FABRICATING & AUTOMATION

Our specialized team of machinists create tools, parts, products, and attachments to solve everyday material handling dilemmas while our team of automation experts focus on robotic engineering, PLC, HMI programming and process automation geared towards your specific manufacturing needs. We deliver world-class expertise by innovating products that help you meet the demands of day-to-day operations.

Let's get started on your next project.



- ✓ Operational Up-time
- ✓ In-house Manufacturing
- ✓ Safety & Security

- ✓ Automated Battery Handling
- ✓ System Design
- ✓ And more!

[info@carneyautomation.com](mailto:info@carneyautomation.com)

[CARNEYAUTOMATION.COM](http://CARNEYAUTOMATION.COM)



- ✓ Product Transfer Systems
- ✓ Below-The-Hook Devices
- ✓ Storage Systems

- ✓ Ergonomic Equipment
- ✓ Forklift & Picker Attachments
- ✓ And more!

[info@carneyfabricating.com](mailto:info@carneyfabricating.com)

[CARNEYFABRICATING.COM](http://CARNEYFABRICATING.COM)



## HAVE ADDITIONAL QUESTIONS? GET IN TOUCH

---

[sales@carneybatteryhandling.com](mailto:sales@carneybatteryhandling.com)  
[www.carneybatteryhandling.com](http://www.carneybatteryhandling.com)

Tel: 1.905.564.0303  
Toll free: 1.866.THE.BULL

*Due to continuous product improvements, specifications are subject to change without notice. Some systems and features shown may be optional at extra cost.*

©2024 Carney Battery Handling Ltd.  
HGC\_specifications\_NA