

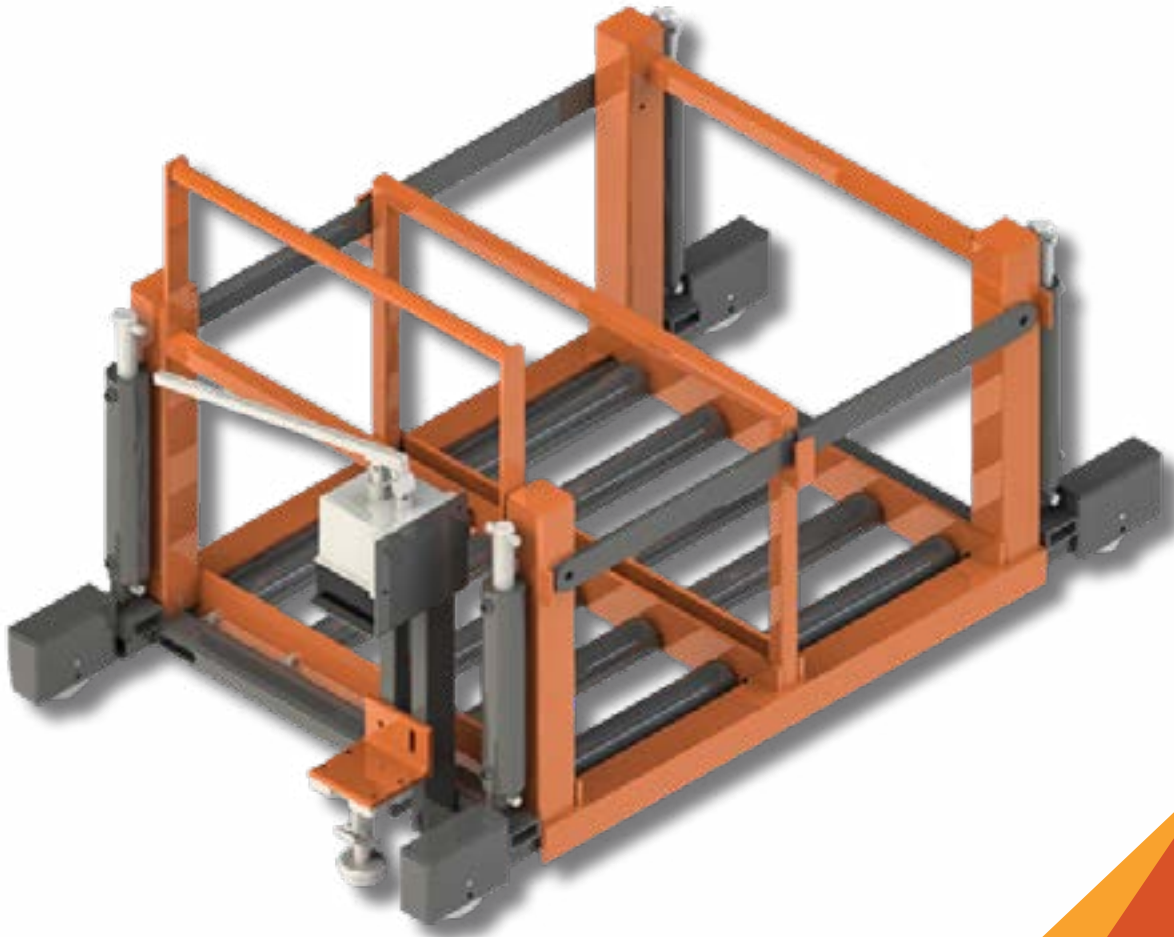

MCC

MANUAL CHANGE CART

BATTERY HANDLING MADE SIMPLE





MANUAL CHANGE CART

If your operation includes a small fleet of pallet trucks and order picker batteries, a manual extractor remains a low-cost, yet effective solution. Engineered to allow safe and effective manual battery changes with minimal effort, the MCC operates within its guide channels. The operator benefits from integrated battery stops, foot braking and loading and unloading from both sides of the system.

The MCC hydraulic pump system quickly raises and lowers the platform to support multiple roll-out heights or roller stands as required. The dual roller system also allows for the staging of fresh batteries to further improve change times.

LOW-VOLUME EFFICIENCY

The MCC is perfect for smaller operations will lower battery changing needs. Accommodating up to 30 batteries with a change time of 4-5 minutes per battery.

DESIGNED TO ASSIST

The MCC is designed to assist with the manual changing of roll-out forklift batteries. With two bays, its able to hold two batteries at a time.

BATTERY PROTECTION

A built-in backstop and safety stop allows for loading and unloading from both sides.

DURABLE ROLLER BEDS

The dual roller beds reduce change times and allow for staging of fresh batteries. The rollers are easy to service and are durable for long-lasting performance.

WARRANTY

Every unit comes with a standard 1-year warranty for your protection.



KEY FEATURES + OPTIONS

- ✓ Custom colours available
- ✓ Safety stop to limit battery movement
- ✓ Non-slip rollers
- ✓ Foot activated braking system
- ✓ Affordable & compact
- ✓ Full battery room packages available including roller stands
- ✓ Hydraulic lift
- ✓ Push rail
- ✓ Battery Gates
- ✓ Durable construction
- ✓ Floor track & guide system

GENERAL SPECS

Capacity	3,500 lbs / 1,587 kgs
Service weight	713 lbs / 32 kgs
Standard Colours	Orange / blue
Roller Diameter	3" / 76.2 mm

MODEL-PART NUMBER BREAKDOWN

Example: MCC-2-18-41-12

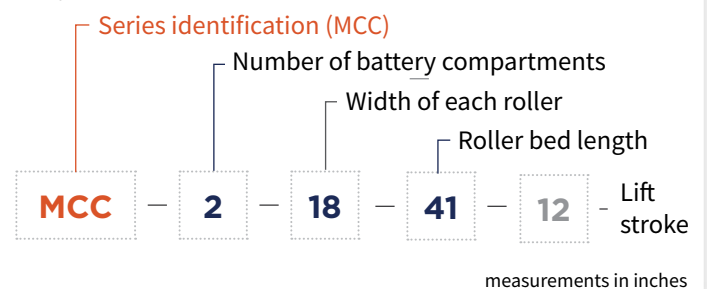

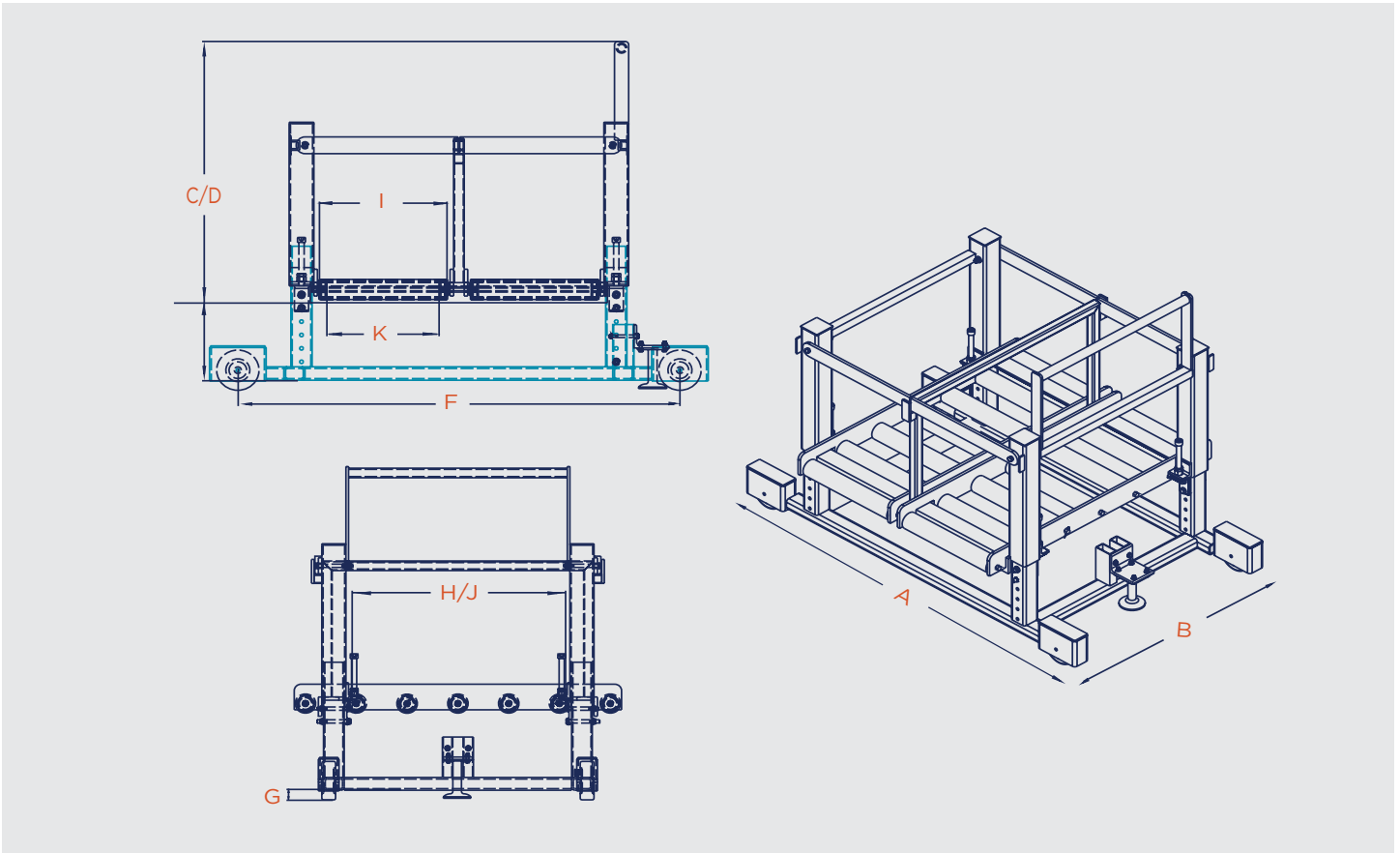

DIMENSIONAL DATA

MCC-2-18

A	Overall length	69.75"	1771.7 mm
B	Overall width	40.5"	1028 mm
C	Overall height (raised)	52"	1321 mm
D	Overall height (lowered)	40"	1016 mm
E	Roll-out height (raised/lowered)	16.5"/4.5"	419 mm/114.3 mm
F	Wheel base	61.75"	1568.5 mm
G	Ground clearance	1"	25.4 mm
H	Battery compartment length	39.5"	1003.3 mm
I	Battery compartment width	18"	457.2 mm
J	Maximum battery length	39.5"	1003.3 mm
K	Maximum battery width	17"	432 mm



FABRICATING & AUTOMATION

Our specialized team of machinists create tools, parts, products, and attachments to solve everyday material handling dilemmas while our team of automation experts focus on robotic engineering, PLC and HMI programming and process automation geared towards your specific manufacturing needs. We deliver world-class expertise by innovating products that help you meet the demands of day-to-day operations.

Let's get started on your next project.



- ✓ Operational Up-time
- ✓ In-house Manufacturing
- ✓ Safety & Security

- ✓ Automated Battery Handling
- ✓ System Design
- ✓ And more!

info@carneyautomation.com

CARNEYAUTOMATION.COM



- ✓ Product Transfer Systems
- ✓ Below-The-Hook Devices
- ✓ Storage Systems

- ✓ Ergonomic Equipment
- ✓ Forklift & Picker Attachments
- ✓ And more!

info@carneyfabricating.com

CARNEYFABRICATING.COM



HAVE ADDITIONAL QUESTIONS? GET IN TOUCH

sales@carneybatteryhandling.com
www.carneybatteryhandling.com

Tel: 1.905.564.0303
Toll free: 1.866.THE.BULL

Due to continuous product improvements, specifications are subject to change without notice. Some systems and features shown may be optional at extra cost.

©2024 Carney Battery Handling Ltd.
MCC_Specifications_NA